

A new approach for the determination of tensile and shear strengths of normal weight concrete

E. I. Al-Sahawneh

Civil Engineering Department, Faculty of Engineering Technology, Al-Balqa' Applied University, Jordan

Abstract: - The present study considers the idealized failure configuration of two cylindrical concrete specimens, geometrically and physically analogous under the action of an axial compressive load. Geometric analysis of two cylindrical specimens with different aspect ratios after failure allows introducing a concept of fracture angle, which is assumed to be constant for the same concrete grade, and its value is a function of concrete strength. Knowing the angle of the fracture plane, two equations were proposed to estimate the mechanical properties of concrete. The practical significance of the prediction value of the fracture angle and the equations presented for tensile and shear strength of concrete is verified through theoretical analysis and the results of test data.

Keywords: - Direction angle of fracture plane, Non-standard Cylinder, Tensile strength, Shear strength, Stress ratio

I. INTRODUCTION

The direct compression test on concrete is a worldwide standardized method performed by casting cube, cylinder or prism. The aim of the test is to determine the characteristic compressive strength. Shear and tensile strength are similarly important required mechanical properties. Tensile strength, despite its low magnitude, is of foremost significance in designing water retaining structures, pavement slabs and concrete members and structures that transmit loads primarily by direct tension rather than bending as silos, tanks, shells, ties of arches, roof and bridge trusses. In the meantime, shear strength is essential in reinforced concrete beams to control the diagonal cracking under flexure. However, so far there is no direct practical standardized method to evaluate the tensile and shear strength of concrete despite the different tests suggested by several researchers.

1.1. Tensile Strength

The tensile strength of concrete can be attained approximately from different tests, such as direct pull tests on briquettes or on molds resemble the dumb-bell shape [1], flexural tests on beams, splitting tests on cylinders or cubes, ring-tensile tests [2] and double-punch test [3]. It has been well established that the simplest and the most reliable method, which typically provides a lower coefficient of variation is the splitting tensile standardized test of a cylindrical specimen (also known as the Brazilian test). In countries where the compressive strength is determined from cubes rather than from cylinders, the tensile strength is obtained using a split cube or a cube specimen tested diagonally. However, there are a lot of disadvantages related to each of these tensile tests. For example, Neville claims that direct application of pure tensile force, without minor eccentricity, is difficult and is further complicated by secondary stresses produced by the grippes or embedded studs. Winter and Nelson state that majority of the indirect tests are based on the assumption that concrete is an elastic material and do not yield the true concrete tensile strength. Because of these difficulties and problems, there is no standardized test for direct tension.

National building codes have tried to predict the tensile strength using test results and empirical approaches based on the compressive strength. One of the most commonly used equations relating compressive and tensile strength of concrete evaluated by indirect test is the flexural test (ASTM C78 or C293) known as the modulus of rupture, which characterizes the apparent tensile strength of concrete beams. American Concrete Institution (ACI 318-14), code Section 9.5.2.3, defines the modulus of rupture f_r for use in calculating the cracking moment and deflection for concrete as:

$$f_r = 0.62 \lambda \sqrt{f'_c}, \quad (\text{SI units}) \quad (1)$$

Where:

f'_c = specified compressive strength of standard concrete cylinder 150dia x 300mm.

λ = factor ranges from 0.75 to 0.85 for lightweight concrete and equal to 1 for normal weight concrete.

The other alternative standard indirect test is the splitting tensile test (ASTM C496 or C330) carried out periodically to compare with the modulus of rupture. ACI 318-14 Code Section 8.6.1 defines the relationship

between average splitting tensile strength f_{ct} and the specified compressive strength of the concrete being used is approximately equal to:

$$f_{ct} = 0.56\lambda\sqrt{f'_c}, \text{ (SI units)} \quad (2)$$

The splitting strength f_{ct} can be used to estimate the direct tensile strength f_t , by multiplying by a conversion factor of 0.9, as given in the CEB-FIB Code [4] and by Hannant et al. [5].

Representative values of tensile strength obtained from tests and measures of variability reported by ACI Committee 224 are shown in Table 1.

Table 1. Relation between compressive strength and tensile strengths of concrete

Compressive strength of cylinders.(MPa)	Strength ratio	
	Modulus of rupture to compressive strength	Direct tensile strength to compressive strength
6.9	0.23	0.11
13.8	0.19	0.10
20.7	0.16	0.09
27.6	0.15	0.09
34.5	0.14	0.08
41.4	0.13	0.08
48.2	0.12	0.07
55.1	0.12	0.07
62.0	0.11	0.07

From test results of cracking strengths and regression analysis to evaluate the direct tensile stress for cylindrical concrete specimens, J. J. Kim and M. R.Taha [6] assumed the following relations:

$$f_{ct} = 0.49\sqrt{f'_c}, \text{ (SI units)} \quad (3)$$

$$f_{ct} = 0.85\sqrt{f'_c}, \text{ (SI units)} \quad (4)$$

$$f_{ct} = 0.34\sqrt{f'_c}, \text{ (SI units)} \quad (5)$$

A.Ghaffar et al. [7] suggested a new approach for the experimental determination of true tensile strength of concrete and a comparison of different strengths calculated from direct and indirect methods has led to the following relations:

$$f_t = 0.66f_{ct}, \text{ (SI units)} \quad (6)$$

$$f_t = 0.3f_r, \text{ (SI units)} \quad (7)$$

Many equations have been proposed, as shown in Table 1, for relating the splitting tensile strength and the compressive strength. These equations are generally in a form of:

$$f_{ct} = n.(f'_c)^k, \text{ (SI units)} \quad (8)$$

Table 1: Values of n . and k given by [8]- [11]

Source	n	k	Remarks
ACI318-14 [8]	0.56	0.5	Normal weight concrete
Raphael [9]	0.313	0.667	Normal weight concrete
Oluokun et al [10]	0.294	0.69	Normal weight concrete
Arioglu et al.[11]	0.387	-0.37	For concretes up to 120 MPa
Soty Ros et al. [12]	0.2	0.8	Concrete at early age with different types of cements

1.2. Shear Strength

The method of testing and the procedure of analysis for determining the shear strength remain a matter of dispute (Collins, Bentz, Sherwood, and Xie, 2007). This is mainly due to its complexity, impracticality and inadequacy of some previous experiments that were done generally to define a complete and adequate theory for shear (Leonhardt 1970). It was noticed that specimen subjected to pure shear failure mode (mode II) fails because the damaged section very often doesn't coincide with the tested section and a tensile mode (mode I) growth governs. Investigators (Ingreffea and Panthaki, 1985; Bazant and Pfeiffer, 1986; Swartz and Taha, 1990; Pettersson, 2002; Hawong et al., 2003; Derradj and Kaci, 2007 Wong et al., 2007; Ridha Boulifa et al., 2012) raised doubt on the reliability and the different results of tests. Fig. 1 illustrates a collection of shear tests on mode II.

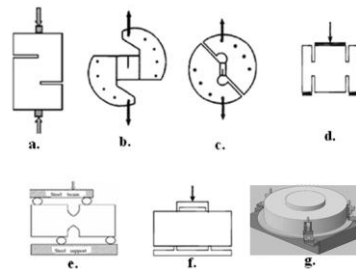

Fig.1. Geometries and loading configurations: **(a)** push-off specimen according to Mattock and Hawkins (Mattock, 1972); **(b)** mixed-mode device according to Richard (Richard, 1981); **(c)** mixed-mode device according to Izumi et al. (Izumi, 1986); **(d)** double-shear test for cylinder specimen according to Luong(Luong, 1990) **(e)** according to losipescu(losipescu, 1967); **(f)** according to Ha Ngoc Tuan et al (Ha Ngoc, 2006);and **(g)** according to Ridha Boulifa(Ridha, 2012).

For pure shear stress τ_c , Sen (1955) recommended the relation:

$$\tau_c = 0.0172(f'_c)^{0.741}, \quad (\text{SI units}) \quad (9)$$

Ha Ngoc Tuan et al [13] suggested, as a result of testing concrete under direct shear test, a linear relationship between shear strength and compressive strength as:

$$\tau_c = 0.1f'_c + 2.03, \quad (\text{SI units}) \quad (10)$$

Another popular test method for the determination of the shear strength of concrete is to load reinforced beams without web reinforcement for bending up to shear; the shear resistance of the beam at a diagonal (i.e., the *shear cracking strength* v_c of the concrete) can be calculated from the ultimate load and the characteristics of the specimen (i.e., dimensions, reinforcement, etc.). This shear strength is not identical with the direct shear strength and is not pure shear either. Viest and others (Viest. 1959; Hognestad et al., 1964. Placa and Regan [14] placed a limit of $0.9(f'_c)^{0.33}$ (in SI units) on the maximum estimated value of ultimate shear using a random data of about 200 beams. A G Mphonde and G C Frantz [15] developed an equation for shear strength of rectangular reinforced beams using regression analysis, in such a form:

$$v_c = 1.92(f'_c)^{0.33} + 0.48, \quad (\text{SI units}) \quad (11)$$

Abdul Ghaffar et al [16] developed equations based on an extensive experimental study carried out on rectangular reinforced concrete beams without web reinforcement. Results of the study show, that the concrete shear capacity ranges from $0.14(f'_c)^{0.5}$ to $0.15(f'_c)^{0.5}$ (in SI units) before any cracking is observed.

According to Bentz et al. 2004, design codes are frequently changing and commonly becoming more stringent, so that structures that were designed several decades ago typically do not comply with the requirements of current codes. According to ACI318-14, the lower-bound limit for the average shear stress at diagonal cracking provided by concrete for non-prestressed members subjected to shear and flexure can be calculated from the following equation:

$$v_c = 0.17\lambda\sqrt{f'_c}, \quad (\text{SI units}) \quad (12)$$

And the upper-bound limit is restricted to

$$v_c = 0.29\lambda\sqrt{f'_c}, \quad (\text{SI units}) \quad (13)$$

The aforementioned expressions of shear stress are usually empirical formulations proposed to conform to a wide range of reported numerical values for shear test results.

II. RESEARCH SIGNIFICANCE

The study investigates a macro scale fracture process of concrete cylinders under axial compression. It takes into account the mixed mode fracture phenomena (the implication of the opening mode besides the sliding mode which was employed and studied before (Sih 1984, Comninou 1990, Yuuki et al 1994, Ohtsu et al 2011)). The main objective is the development of model equations to predict both the tensile and shear strength of normal weight concrete from the direct compression test of two cylinders separately in the existence of friction between the loading platens and concrete cylinders. The two cylinders should have a same cross-sectional area, but are of different heights. The aim of employing two cylinders is to introduce a new concept of characteristic fracture angle or the direction angle of the failure plane as a function of concrete strength.

III. THE DIRECTION ANGLE OF THE FAILURE PLANE AND THE ESTIMATION OF SHEAR AND TENSILE STRENGTHS

Many studies built on micro and sub-micro structure of concrete (Bažant Z.P, 1980; Saouma.V., 1985; Carpinteri.A, 2002; Issa et al. 2000; J.K.Kim, 2002 Hoover. C.G, 2013) have been assigned different fracture modes and size effect phenomena to the geometric components of inevitable micro-cracking (crack sizes, crack orientations, sharp cracks tip, crack bridging) which, as a result, affect the tortuous trajectory of the main crack. Although it is well-known that these interpretations hold probabilistic nature, and all actual construction materials act differently under loading despite possessing, to one degree or another, invisible cracks or voids.

It is experimentally proved that, under axial compression tests, the final fracture character of two cylinders made from the same concrete mix and tested under the same condition is identical. The failure shape is simply characterized by cleavage along inclined planes and by separating the side portions. Such fracture pattern is attributed to the friction between the loading platens and concrete cylinder which leads to two relatively undamaged cones, as shown in Fig.2. If the friction were eliminated, the cylinder would expand more laterally and exhibit a columnar splitting failure. The cylindrical specimens of high-strength concrete often fail by laminar splitting even though the specimen ends are constrained, i.e., additional resistance against laminar splitting provided by the specimen ends is not enough to induce inclined sliding failure. This type of fracture of high-strength concrete can be attributed to other reasons that may have a close relationship with this study.



Fig. 2.Fractured test specimen at failure.

Based on laboratory tests, the behavior and fracture characteristics of a concrete specimen up to the peak load limit P_u are characterized by the onset of unstable crack growth, but beyond this limit, cracks become unstable and self-propagating until complete discontinuity of major cracks, and failure occurs (Kotsovos and Newman, 1977 and Chen, 1982). Consequently, peak load satisfies simultaneously both observed patterns of fracture, either by splitting parallel to the applied load or by displacement (mixed mode fracture) along the envelope of the slip lines (contour of growing up main crack- opening displacement). Thus, it be concluded that the main crack begins to propagate under the applied load P at the moment of achieving the equality:

$$P = P_u \quad (14)$$

Besides, the test results show that the height-diameter ratio will influence the compressive strength of the specimen being tested. Measured strength, as shown in Fig. 3, increases as the height-diameter (h/d) ratio decreases (Tucker, 1945; Price, 1951; Kesler, 1959; Bazant, 1987; Chung, 1989; MacGregor, 1994; Kim, 2002; and others)

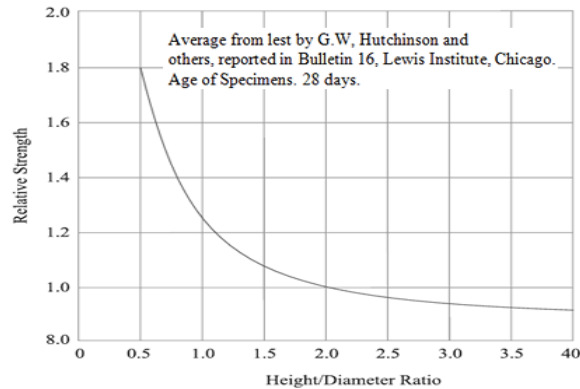

Fig.3. Height/Diameter ratios and compressive strength (U.S. Bureau of Reclamation, 1975)

Murdock and Kesler [17] also found that the correlation coefficient for the influence of h/d ratio on the strength of the cylinders is not constant, but depends on the level of concrete strength. High strength concrete is less affected than the low strength concrete. Fig.4 shows the influence of h/d ratio on cylinder strength for different levels of strength.

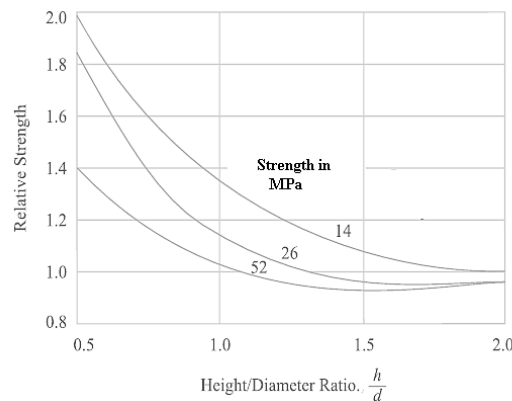

Fig.4. The general patterns of influence of h/d ratio on cylinder strength.

In light of the foregoing, consider an idealized failure configuration of two cylindrical concrete specimens, geometrically and physically analogous, under axial compressive load. The two specimens under consideration should have the same properties, namely concrete mix, direction of casting, cross-sectional area, rate of loading and condition of curing in order to achieve similarity. Referring to Fig.5, where h is the height of specimen; d_c is the diameter and ϕ is characteristic angle of sliding plane. The angle ϕ is assumed a physical material property, and its value is constant for the same grade of concrete. The value ϕ increases with increasing concrete strength. It is of interesting to point out that J.K.Kim [18] suggests that the angle ϕ has variable values for the same grade of concrete since the larger the ratio h/d the smaller value of ϕ is expected. In Fig. 5, for cases $h \geq d_c \tan \phi$ failure occurs under nominal compression stress f'_c , assuming that h is not too large to cause failure by buckling, but for cases $h < d_c \tan \phi$, failure takes place under nominal compression stress f'_{c1} , where

$$f'_{c1} > f'_c \quad (15)$$

The stresses f'_c and f'_{c1} are generated by non-through equilibrium cracks, in addition to the stresses induced by the interaction between the interfaces of the envelope of slip planes, which specify the path of main cracks (as represented in Fig.5 by the dashed lines between regions A and B).

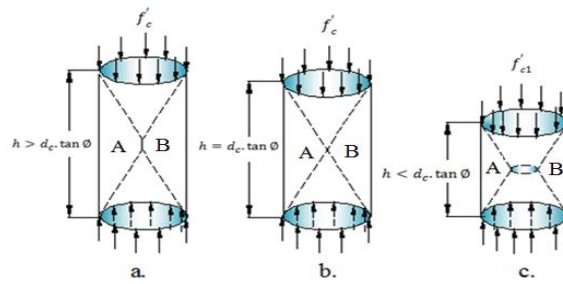

Fig.5. Failure modes of concrete cylinders with different h/d ratio.

For specimen c in Fig.5, plastic flow occurs in the form of two mutually intersecting slip bands in the middle of the sample forming, at the median plane, a plastically deformed apparent surface layer (barrier). In this constrained state, main cracks (non-through cracks) propagate from the two loaded end faces of the sample without intersection of cracks tip. On the contrary, for specimen a and b in Fig.5, failure takes place by through cracks running from one loaded end face to the other end face intersecting at the geometrical center or close to it in a free condition. In this modeling, stress and strain are assumed uniformly distributed throughout the fracture zone in front of the main crack path.

Suppose that up to failure over the expected direction of the inclined interface (envelop of slip bands) which direction defined by normal n , act an average normal stress σ_n parallel to normal n and an average shear stress τ tangent to it. Thus, at any instant of compressive loading on the specimen, the state of stress on the inclined surface can be expressed as follows:

$$\sigma_n = f(\sigma, \phi) \text{ and } \tau = f(\sigma, \phi) \quad (16)$$

σ = compressive stress imposed by the ram on top of the specimen. Therefore, crack assumed to propagate along the slip line only when

$$\sigma_n = \sigma_t \text{ and } \tau = \tau_v \quad (17)$$

Where σ_t and τ_v are, in general terms; the maximum stresses equivalent to tensile and shear stresses of concrete cylinder specimen with variable ratio h/d , respectively.

As shown in Fig.6, the angle of sliding plane is assumed an invariant physical property for the same grade of concrete. The stresses acting on the sliding surfaces for the two cylinders can be expressed in the form of the following inequalities:

$$f_t^* > f_t, \text{ and } f_v^* > f_v \quad (18)$$

f_t^* and f_v^* = equivalent to tensile and shearing stresses, respectively, for specimen with $h < d_c \tan \phi$.

f_t and f_v = equivalent to tensile and shearing stresses, respectively, for specimen with $h \geq d_c \tan \phi$.

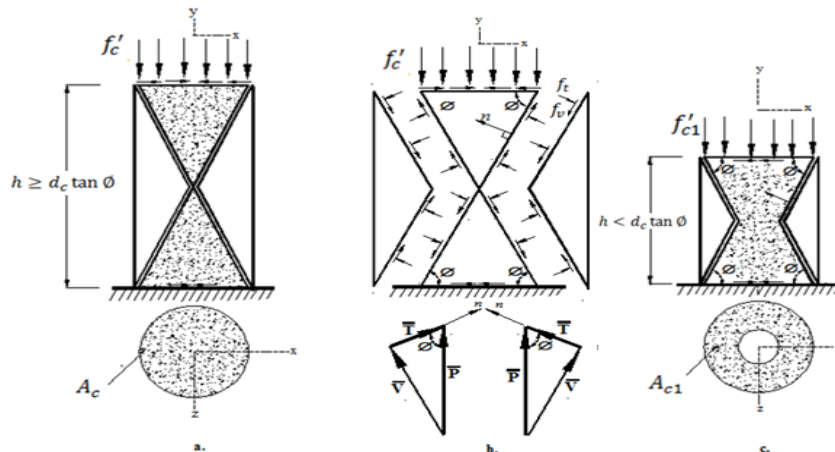

Fig.6. Idealized failure configuration of concrete cylinders with variable heights and constant diameter.

These inequalities may be adjusted within the framework of Rice's J -integral disregarding the path-dependence, which in a modified form can be expressed approximately as follows:

$$J = f'_c \cdot A_c = f'_{c1} \cdot A_{c1} = G_f = \text{constant} \quad (19)$$

Where A_c is the projected area of the upper or lower entire fractured lateral surface on the xz -plane for specimen with $h \geq d_c \tan \phi$.

A_{c1} is the projected area the upper or lower entire fractured lateral surface on the xz - plane for specimen with $h < d_c \tan \phi$.

G_f –driving force for crack growth.

Eq. 19 yields

$$f'_c = f'_{c1} \cdot \frac{A_{c1}}{A_c} \quad (20)$$

To develop an equation for the angle ϕ , we carry out a geometrical analysis on the lower part of two specimens after failure. Assume that the first specimen has $h \geq d_c \tan \phi$, Fig.7 (a) and the other, to simplify the procedure of analysis, has $h = d_c$ Fig.7(b and c). From Fig.7(c), which represents the projected area of a lateral surface of a truncated cone on xy - plane, we can write that

$$a = d_c \cdot \frac{1}{2 \cdot \tan \phi}$$

$$d'_c = d_c - a = d_c - d_c \frac{1}{2 \tan \phi} = d_c \left(1 - \frac{1}{2 \tan \phi} \right) = d_c \left(\frac{2 \tan \phi - 1}{2 \tan \phi} \right)$$

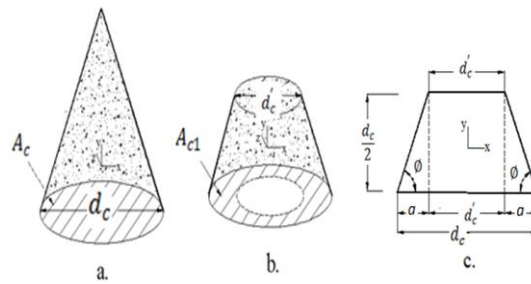

Fig.7 Idealized failure configuration of the lower parts of concrete cylinders. **(a)** For specimen with $h \geq d_c \tan \phi$. **(b)** and **(c)** for specimen with $h = d_c$

For computing the projected area of the lateral surface (A_{c1}) on xz - plane and the ratio between A_{c1} and A_c

$$A_{c1} = A_c - \frac{\pi}{4} \cdot d_c^2 \cdot \left(\frac{\tan \phi - 1}{\tan \phi} \right)^2 = \frac{\pi}{4} \cdot d_c^2 - \frac{\pi}{4} \cdot d_c^2 \cdot \left(\frac{\tan \phi - 1}{\tan \phi} \right)^2 = \frac{\pi}{4} \cdot d_c^2 \cdot \left(\frac{2 \tan \phi - 1}{\tan^2 \phi} \right)$$

So, the ratio

$$\frac{A_{c1}}{A_c} = \frac{2 \tan \phi - 1}{\tan^2 \phi}$$

Substituting the value of the ratio A_{c1} / A_c into Eq. (20) then

$$\frac{f'_{c1}}{f'_c} = \frac{2 \tan \phi - 1}{\tan^2 \phi}$$

Assuming that

$$\frac{f'_{c1}}{f'_c} = \eta = \frac{2 \tan \phi - 1}{\tan^2 \phi}$$

Then

$$\tan \phi = \frac{1}{\eta} \cdot (1 + \sqrt{1 - \eta}) \quad (20)$$

In practice, the stress ratio η should be determined by the results of two tests on specimens with $h = 2d_c$ (standard cylinder 150dia. x 300mm) and the other with $h = d_c$. Choice of the standard height/diameter ratio of 2 is suitable, because a slight departure from this ratio does not seriously affect the measured value of strength and size effect vanishes within this range for normal weight concrete. ASTM C 42-90 states that no correction is required for values of h/d between 1.94 and 2.10. For normal-weight concrete when the stress ratio $\eta = 0.8$ then $\phi = 61.07^\circ$; $\eta = 0.714$ then $\phi = 65.04^\circ$; $\eta = 0.666$ then $\phi = 67.09^\circ$; $\eta = 0.625$ then $\phi = 68.8^\circ$ which practically coincide with the fracture angles computed by different experimental tests of previously published studies.

The tensile and shear stresses are established assuming a mixed mode fracture of an axially compressed concrete standard cylinder with $h \geq d_c \tan \phi$ or $h = 2d_c$. The vector equilibrium condition of the internal forces acting on the free body diagram of the inclined upper lateral surface of the concrete cone, as shown in Fig.6 (b), yields:

$$\vec{P} = \vec{T} + \vec{V}$$

$$|\vec{P}| = 0.5 f'_c \cdot A_c$$

$$|\vec{T}| = |\vec{P}| \cdot \cos \phi = 0.5 f'_c \cdot A_c \cdot \cos \phi = f_t \cdot \cos \phi$$

$$f_t = 0.5 f'_c \cdot \cos^2 \phi \quad (22)$$

$$|\vec{V}| = |\vec{P}| \cdot \sin \phi = 0.5 f'_c \cdot A_c \cdot \sin \phi = f_v \cdot A_c / \cos \phi$$

$$f_v = 0.5 f'_c \cdot \cos \phi \sin \phi \quad (23)$$

$$f_v = f_t \cdot \tan \phi \quad (24)$$

IV. VERIFICATION OF THE PROPOSED RELATIONS

To verify the reliability degree of the developed relations, it is well known that one common way to define concrete shear strength is based on failure curves of concrete in τ - σ space.

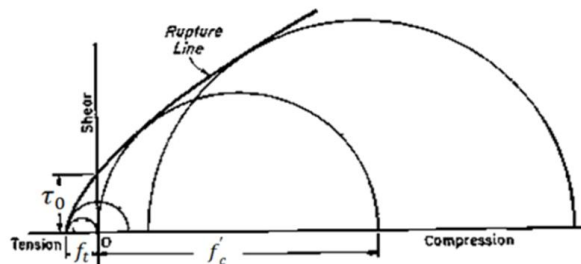

Fig. 8 Failure envelop in σ - τ space

Figure 8 schematically shows such a curve. This curve is an envelope of a series of Mohr's circles [19] obtained from shear test of concrete specimens under uniaxial and multiaxial stress state. The value of shear, where the envelope crosses the vertical axis, is defined as the shear strength, which can generally be expressed by the following formula:

$$f_v = k \cdot \sqrt{f'_c \cdot f_t} \quad (25)$$

The coefficient $k = 0.5 \dots 1$ varies according to the grade of concrete. According to Morsh $k=1$ but the coefficient has been changed several times after Mohr's criticism and, finally, it was replaced by $k = 0.83$.

Mohr's formula of shear strength, which denoted by τ_0 in Fig.8, gives $k=0.5$ in a particular case. This study provides a theoretical basis for the formula (25), which taking into account the relations (22) and (23), and can be easily converted into

$$\begin{aligned}
 f_v &= k \cdot \sqrt{f'_c \cdot f'_t} = 0.5 f'_c \cos \phi \sin \phi \\
 &= k \cdot \sqrt{0.5 f'_c \cdot \cos^2 \phi} \\
 &= 0.707 \cdot k \cdot f'_c \cos \phi
 \end{aligned}$$

This leads to

$$k = 0.707 \cdot \sin \phi \quad (26)$$

The average value of the sliding angle ϕ is adopted from the results of researchers test data: In Suenaga and Ishimaru (1974) concluded that $\phi=57.5^\circ$ based on the Wedge Theory regarding the bearing strength of plain normal weight concrete. In addition, columns tested by Lynn and Sezen (2002), the final crack angle for normal weight concrete ranged from 65° to 71° degrees, with an average of 68° relative to horizontal plane. Therefore, the average slip angle will be 62.75° for the two considered tests. From Eq. (26), the average value of k is

$$k = 0.707 \cdot \sin 62.75 = 0.707 \cdot 0.889 = 0.628$$

The average value of k proposed by Mohr and Morsh equals to 0.66. Ha Ngoc Tuan et al (2007) found the average value of k for all normal and lightweight specimens in the experiment is 0.62 using 3d nonlinear finite element analysis of concrete under double shear test.

According to ASTM C 42, cores for compressive strength testing must have a length-to-diameter ratio between 1.0 and 2.10. For ratios less than 1.94, the compressive strength is multiplied by a correction factor (less than 1) given in ASTM C 42 to correlate the strength of the core to that of a standard concrete test cylinder that has a length-to-diameter ratio of 2. If we use the average angle of slip planes $\phi=62.75^\circ$, then the standard height of the cylinder for a standard test specimen must not be less than:

$$h \geq d_c \tan \phi \geq d_c \tan 62.75 \geq 1.94 d_c$$

The answer totally satisfies the requirement of ASTM C 42.

Table 2 shows the computed values for tensile strength and shear strengths of normal weight concrete by proposed model equations. The approximate tabulated values of compressive for cylinders with $h/d=1$ are obtained by using appropriate strength correction factors from widespread tests data and relevant studies presented by Gonneman in 1925, ACI Committee 224, Mansur and Islam [20] and Satja Muangnok [21].

Table 2. Evaluation of the tensile strength and shear strengths using Eq. 22 and Eq. 23.

f'_c of standard cylinders (150 dia. x 300mm) (MPa)	f'_{ci} of non-standard cylinders (150 dia. x 150mm) (MPa)	Stress ratio η	ϕ in deg.	Direct tensile strength (MPa). Eq.22	Shear strength (MPa). Eq.23
15.15	21.21	0.71	65.04	1.34	2.89
19.00	27.20	0.69	65.73	1.61	3.56
23.40	34.10	0.68	66.26	1.69	4.31
27.80	41.42	0.67	66.90	2.14	5.01
31.90	48.40	0.65	67.41	2.35	5.65
34.80	54.40	0.63	68.21	2.40	5.99
41.50	65.11	0.63	68.31	2.83	7.12
52.70	85.16	0.63	69.06	3.36	8.79

Fig.9 to Fig.12.illustrate graphically the plot of proposed formulas for tensile and shear strengths versus the direct tensile strength, modulus of rupture, splitting tensile strength and shear stresses computed by different researchers.

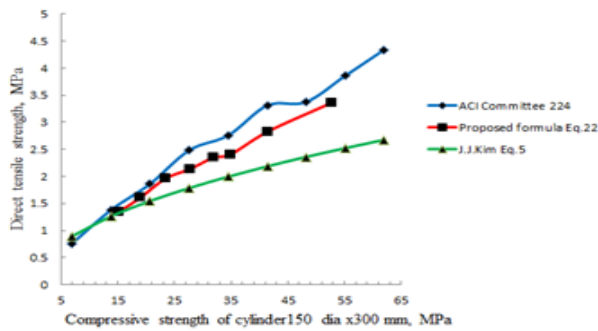

Fig.9 Comparison of the tensile strength computed by proposed formula and the direct tensile strength

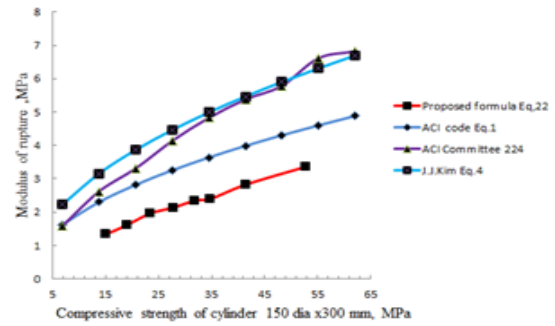

Fig.10 Comparison of the tensile strength computed by proposed formula and modulus of rupture

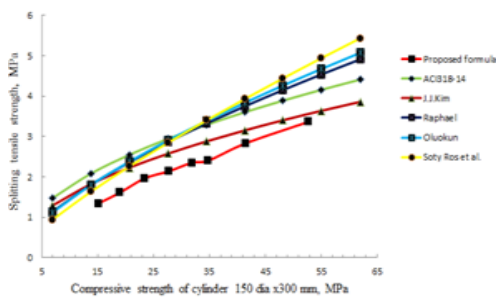

Fig.11 Comparison of the tensile strength computed by proposed formula and splitting tensile strength.

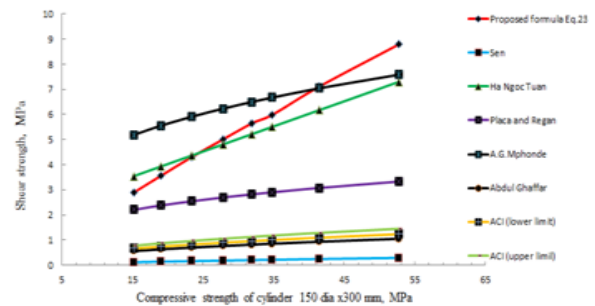

Fig.12 Comparison of shear strength computed by formula and shear strength values by other authors.

V. CONCLUSION

The following results are drawn from this work.

- 1- Introduction of a new concept of fracture angle depending on the ratio of the compressive stress of two cylinders of different height to diameter ratio.
- 2-Model equations for predicting the tensile and shear strengths of normal weight concrete are suggested based on collapse configuration of concrete cylinders.
- 3-It's not empirical equations obtained to satisfy the test results, but they were developed theoretically.
- 4-According to suggested Eq.22, the tensile strength of concrete is about 7.6 % of specified compressive strength of standard cylinder 150 dia.x300, which is slightly different than the percentage values given by ACI committee 224(8.4%) and J.J.Kim (6,7%) of specified compressive strength.
- 4- It is important to note that the suggested tensile strength of concrete in Eq.22 is about 0.517 of the modulus of rupture computed by different researchers referred to in the present work and is about 0.617 of modulus of rupture recommended by ACI 318-14.
- 5- The tensile strength determined by suggested tensile strength of concrete in Eq.22 is about 0.725 of the splitting tensile strength reported by many researchers and is about 0.682 of the splitting tensile strength proposed by ACI 318-14.
- 6- It is noticeable that different testing yields different values of shear strength. The values of shear strength proposed by Eq.23 vary from 16.6 % to 19 % of f'_c , with a weighted average as 17.8%. The weighted average of shear strength determined by Ha Ngoc Tuan is approximately 17.6% of f'_c and is around 22.2% f'_c determined by A.G.Mphonde. The numerical results of shear strength of ACI 318-14 are significantly less than the values of shear strength obtained by Eq.23.

VI. ACKNOWLEDGEMENTS

The author is grateful for the support of the academic members of Civil Engineering Department and their continued assistance in preparation of this work.

REFERENCES

- [1] A.Ghaffar, M. A. Chaudhry and M. Kamran Ali., A new approach for measurement of tensile strength of concrete, *Journal of Research (Science), Bahauddin Zakariya University, Multan, Pakistan.Vol.16, No.1, June 2005, 01-09.*
- [2] Hannant, D. J.,The Tensile Strength of Concrete: A Review Paper, The Structural Engineer, *The Journal of the Institution of Structural Engineers, London, England, Vol. 50, No. 7, July 1972, 253-257.*
- [3] Chen, W. F. and Trumbauer, B. E., Double-Punch Test and Tensile Strength of Concrete, *Journal of Materials, ASTM, Vol. 7, No. 2, June 1972, pp. 148-154.*
- [4] CEB-FIP Model Code for Concrete Structures 1990, ,Evaluation of the Time Dependent Behaviour of Concrete, *Bulletin d'Information No. 199. Comite European du Beton/Federation Internationale de la Precontrainte. Lausanne, 1991, 1-20.*
- [5] Hannant. D. J.; Buckley. K. J.; and Croft. J., ,The Effect of Aggregate Size on the Use of the Cylinder Splitting Test as a Measure of Tensile Strength, *Materials and Structures, V. 6, No. 31. 1973, 15-21.*
- [6] Jung J. Kim and Mahmoud Reda Taha., Experimental and Numerical Evaluation of Direct Tension Test for Cylindrical Concrete Specimens, *Hindawi Publishing Corporation.Research Article,Volume 2014, Article ID 156926.*
- [7] A.Ghaffar. M. A. Chaudhry and M. Kamran Ali., A new approach for measurement of tensile strength of concrete, *Journal of Research (Science), Bahauddin Zakariya University. Multan. Pakistan. Vol.16, No.1, June 2005, 01-09.*
- [8] ACI Committee 318-14 ,Building code requirements for structural concrete (ACI 318-14) and commentary,*American Concrete Institute. Farmington Hills,MI48831.*
- [9] Raphael. J.M., Tensile strength of concrete, *ACI Journal.Proceedings Vol.81. No.2. Mar.-Apr. 1984. pp 158-165.*
- [10] Oluokun. F.A.. Burdette. E.G. and Deatherae, J.H., Splitting tensile strength and compressive strength relationships at early ages, *ACI Materials Journal. Vol.88. No.2. Mar.-Apr. 1991. 115-121.*
- [11] Arioglu, N.. Girgin. Z.C. and Ahoglu. E., ,Evaluation of Ratio between Splitting Tensile Strength and Compressive Strength for Concrete up to 120 MPa and its Application in Strength Criterion, *ACI Materials Journal. Vol.103. No.1. January-February 2006, 18-24.*
- [12] Soty Ros and Hiroshi Shima, ,Relationship between splitting tensile strength and compressive strength of concrete at early age with different types of cements and curing temperature histories, *JCI Proceedings,Vol.35, No.1, 2013, pp427-432.*
- [13] Ha Ngoc Tuan, Hisanori Otsuka, Yuko Ishikawa and Eizo Takeshita ,A study on shear strength of concrete under direct shear test,*JCI Proceedings,Vol.28,No.1,2006.*
- [14] Alexander Placa and Paul E. Regan with a Foreword by A.L.L Baker., "Shear failure of reinforced concrete beams-" *ACI journal, October 1971. title No.68-67. PP: 763-773.*
- [15] Andrew G. Mphonde and Gregory C. Frontz., ,Shear tests of High and low strength concrete beams without stirrups, *Adjournal, title No. 81-32, July-Aug 1984..350-356.*
- [16] Abdul Ghaffar , Afzal Javed , Habib ur Rehman., Development of Shear Capacity Equations for Rectangular Reinforced Concrete Beams, *Pak. J. Engg. &Appl Sci. Vol. 6, Jan., 2010 , 1-8.*
- [17] Murdock J.U. and Kesler C.L., Effect on Length to Diameter Ratio of Specimen on the Apparent Compressive Strength of Concrete, *ASTM Bulletin. April 1957.*
- [18] Kim, J.K, S, T.Yi. and Yo, S.H, Size effect of concrete compressive strength for the non-standard cylindrical specimens,*Fracture Mechanics of Concrete Structures,Proceedings Framcos-3.Aedificatio Publishers, D-79104 Freiburg, Germany, 1973-1983.*
- [19] H. Tanaka. I. Yoshitake. Y. Yamaguchi and S.Hamada: ,Experimental Study on the Shear Strength of Concrete Elements Subjected to Pure Shear Stress, *Journal of Material, Concrete Structure and Pavement Vol.746, pp.205-214, 2003.*
- [20] Mansur, M. A., Islam, M. M. 2002, ,Interpretation of Concrete Strength for Nonstandard Specimens. “, *Journal of Materials in Civil Engineering ,151-155.*
- [21] Satja Muangnok,Effect of specimen shape and size on compressive strength of high-strength concrete, Thesis, *Kasetsart University, 2008.*